

INTELLIGENT SHOPPING TROLLEY WITH DOOR MECHANISM

[1] S. Jagan Mohan Rao, [2] O. Saranya, [3] K. Satvika, [4] Y. Mahendra

[1] Professor, Phd, Dept of ECE, Ramachandra college of Engineering, Eluru, Andhra Pradesh, India.

[2] [2][3][4] B. Tech student, Dept of ECE, Ramachandra college of Engineering, Eluru, Andhra Pradesh, India.

Abstract

For example, in a grocery store, a smart shopping system may connect all of the items. Low-cost RFID tags may be added to each item in an IoT system, which may be read by a smart shopping cart's RFID reader when the item is put in the cart. To avoid lengthy lines at the register, clients may now pay for their purchases using their smartphones. This system may also be coupled with RFID scanners, enabling it to maintain inventory track and, if required, communicate stock changes to a central server. Additionally, inventory management is simplified thanks to the use of RFID readers instead of laborers who must manually scan every item in the system. Design criteria, a prototype system, and a secure communication protocol are some of the methods used in this study to prove the system's viability in the real world. We believe this is the first time that a smart shopping system with security in mind has been offered.

key words

RFID, Shopping Trolley, Auto Billing, Door Mechanism.

1. INTRODUCTION

Computer and communication capabilities may now be found in a wide range of everyday objects. As a result, the industrial, financial, and environmental systems have undergone a new revolution. Managing data, communicating wirelessly, and making snap decisions in real-time are all adversely affected by this issue. Security and privacy issues in the IoT need the usage of lightweight cryptographic algorithms. Smart homes, wearable gadgets, and e-health systems have seen a lot of activity in the IoT research sector. Because it has gotten so little attention in the scientific world, RFID is the subject of this investigation. RFID readers may be used to monitor a smart shelf if each item for sale is equipped with a tag that can be read by a reader. There are many benefits to this on the surface, including an RFID-equipped shopping cart that may automatically scan items and generate billing information when they are put in a smart cart. Customers save time by not having to stand in long checkout lines. A server may receive real-time status updates from the smart shelves, which are equipped with RFID readers. If an item is out of stock, the server may tell the rest of the crew to order more. Keeping track of inventory is easy for the store since all products are

automatically read and recorded. Since the range of UHF passive tags is 1 to 12 meters, For a smart retail system, we suggest RFID technology. Researchers have looked at using low/high-frequency RFID in the past, however, this technology has limited ranges and relies on users physically scanning goods. Our smart cart design components are an RFID reader, microcontroller, LCD touchscreen, and Wi-Fi module. The RFID reader on the smart cart may be used to scan the contents of a cart. The cart's microcontroller has LCD buttons for user interaction. Wireless technology was selected for the smart cart's link to the server since it is low-power and affordable. An IR sensor is used to count things on smart shopping carts. IR Sensors may also add products to the shopping cart if a user removes an item's RFID tag and places it in the cart. A consumer can pay for their item using the billing information provided by the smart cart. You may verify that the cart has been paid for by placing RFID readers close to it.

A whole new set of privacy and security issues are raised by smart buying systems that have never been explored previously. There are several ways an attacker may interfere with the wireless connections between the server, smart carts, and items in such a system if no sufficient security measures are taken. When a competitor has easy access to commodity circulation, they may learn about customer preferences, and this information can be used for financial strategic goals by the store's rivals. A smart buying system hasn't been studied in the same way that security and privacy have been studied in other disciplines.

This is a ground-breaking study into the development of a safe and efficient smart shopping system. The following is a list of our contributions.

The smart shopping system we propose has a comprehensive design, which we discuss in full, together with all of its associated functionalities.

Using UHF RFID technology, a smart retail system's connections can be supported. For the first time, our method provides an accurate range of readings for each item.

This is the first time a secure protocol for communicating with smart commerce systems has been developed. An assessment of the protocol's computation and communication complexity and security are also performed.

For example, we've developed an accurate and automated reading feature in our prototype smart shopping system.

2. EXISTING SYSTEM

Previously, the design of smart shopping systems centered mostly on Barcodes, Barcodes with limited ranges, and required users to manually scan things with the scanner. The current method relies on people to check the quality and quantity of products in supermarkets, which might lead to human errors. A waste of time, additional effort, and human errors might result.

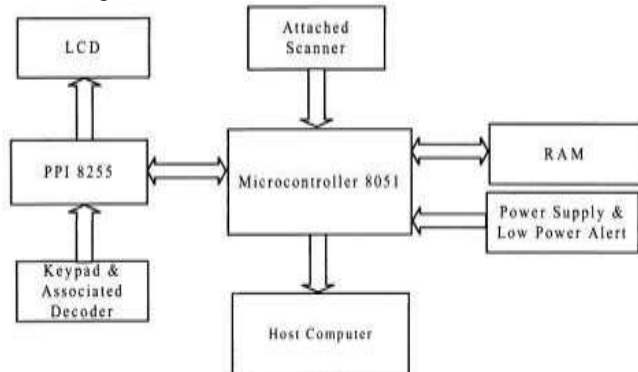

3. PROPOSED SYSTEM

The RFID-based smart trolley consists of the trolley that is incorporated with the RFID reader. As soon as the customer places the product, they want to buy into the trolley, the RFID reader attached to the trolley detects the RFID tag number of the product to identify it. Each RFID tag number is linked to a product it describes. All the information regarding the product associated with the RFID tag in the database can be retrieved using a centralized server. All the activities are coordinated together using a Microcontroller. The product can be directly scanned by the reader and if the customer wishes to remove any product, they just have to again scan the product, then the product should be deleted. After the purchasing product total amount of the bill is generated and displayed on the LCD of the trolley and also in the billing section. When a customer goes to the billing section, he has to only pay the amount.

A. System Architecture

A PID (Product Identifier) is assigned to each trolley (PID). The PID gadget transmits its data via Wi-Fi to a central billing system, which automatically calculates the net price of all bought goods. Depending on the customer's trolley ID number, the billing or packaging department may supply their billing information. No cash collector is needed even if the net amount is paid by debit or credit card. Wireless transceivers and servers/systems that link to the product database are part of the central billing system.



Central automated billing system

B. Proposed block diagram:

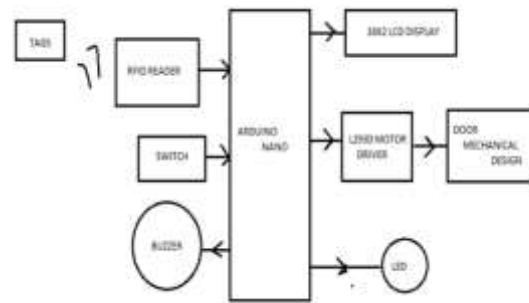

Block diagram of the proposed system

C. System Working

Every shopping cart is linked to a device that comprises an RFID reader, a microcontroller, and a Wi-Fi connection. Each trolley will transmit the item information to the main billing server to determine the final amount. To communicate information about each trolley, we employ Wi-Fi rather than Bluetooth or Zigbee.

When a consumer goes inside the business and takes their shopping cart, the workday officially begins. The RFID scanner in the trolley is linked to an Android app to produce billing. When the customer inserts the items in the RFID reader, the data is read and transferred to the EPROM through the microcontroller. This data is sent over Wi-Fi to the main server, where it is utilized to extract the item's cost and display it on the cart's LCD. When a customer removes an item from the cart, the cost of that item is subtracted from the final bill. Finally, the bill is calculated on the principal server.

D. Algorithm

- Step1: Start
- Step2: Initialize System
- Step3: Place the RFID-tagged object in the cart.
- Step4: The RFID reader reads the tag information
- Step5: The microcontroller receives the data from the reader.
- Step6: microcontroller to transmit data to the LCD.
- Step7: The server will figure up the total and return it to the cart.
- Step8: The final bill is shown on an LCD screen.
- Step9: If the client wants to continue, they should click on
- Step10: Otherwise, go to Step12
- Step10: Register for the Android app
- Step11: The bill is generated by the server and then printed out.
- Step12: Stop

E. Flow Chart

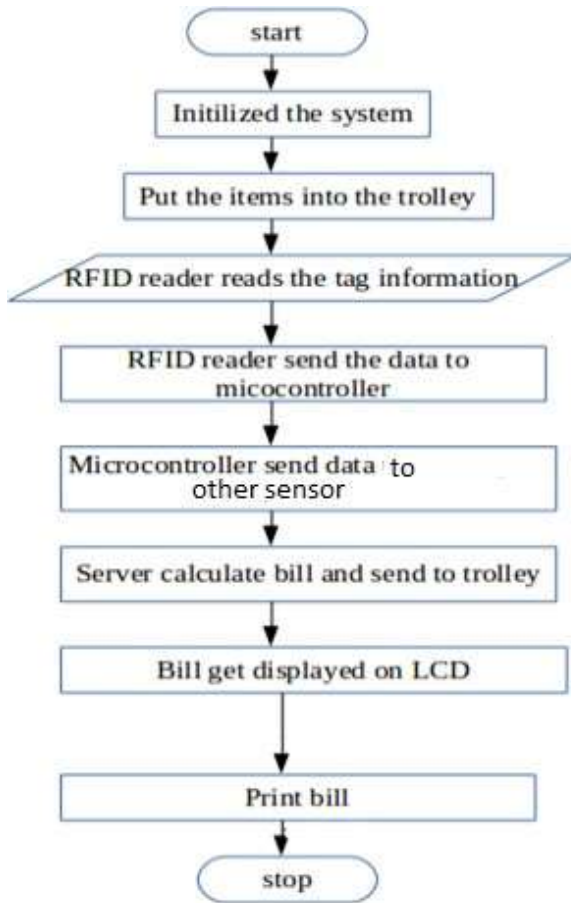

Other capabilities include modulation and demodulation of an (RF) signal as well as storage and processing of information. The second component is an antenna, which serves as both a receiver and a transmitter of data. Tags printed directly onto assets may now be identified using chip-less RFID, which eliminates the need for an integrated circuit and enables lower-cost tag printing.

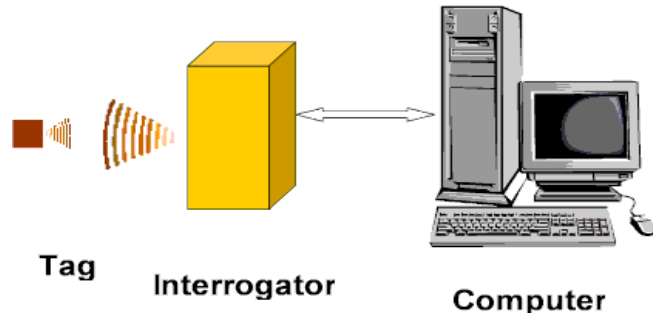

The Transponder (tags that are connected to the item) and the Interrogator are the two most important parts of a Radio Frequency Identification system (RFID reader). When employing a wireless RFID reader, communication between an RFID reader and a tag does not need a direct line of sight.

C. RFID Transponder/Tag

An RFID transponder is a tiny microchip that is coupled to an antenna, making it a next-generation barcode. It is possible to read them through most materials save for conductive ones like water or metal, but only with a little tinkering and repositioning.

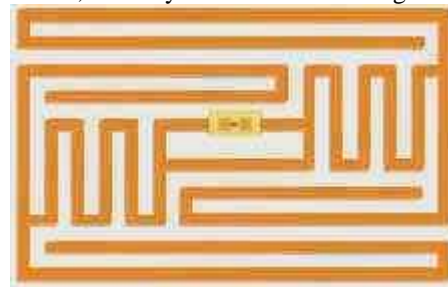

Fig: RFID Tag

4. HARDWARE DESCRIPTION:

A. ATMEGA328 Microcontroller

On the atmega328's physical side, programming is done using an integrated development environment (IDE) and a microcontroller board. It accepts a large number of inputs while also controlling a large number of outputs (such as the lights and the engine) (such as switches). The atmega328 microcontroller program can run on Windows, Macintosh, and Linux, unlike most other microcontroller frameworks (OS). Arduino programming is accessible to novices and experts alike. Arduino is a wonderful tool for individuals who wish to build a more complex desktop computer. Simple microcontroller board and programming environment for building open-source board applications

B. RFID (Radio Frequency Identifier)

Using RFID tags or transponders, which are electronic devices that transmit and receive radio waves, an automated identification system may store and retrieve data about objects. An RFID tag may be connected to or placed in a product, animal, or person to identify it. Some tags can be read from as far away as a few meters away, even if the reader is not looking at them. A typical RFID tag consists of at least two components.

D. LCD (Liquid Crystal Display)

In a liquid crystal display (LCD), pixels are arranged in front of a light source or reflector to create a tiny, flat display. Between two clear electrodes and two polarizing filters, two rows of liquid crystal molecules are perpendicular to each other. The light traveling through one would be blocked by the other if there were no liquid crystals between them. Because of the polarization-altering properties of liquid crystals, a second filter may be used without distortion.

Interacting with the outside world, software must use equipment that can directly interface with a human person, such as keyboards and monitors. An LCD is a typical addition to gaming consoles. 16x1, 16x2, and 20x2 LCD monitors often link to controllers. A single line of 16 characters indicates that each line will have a maximum of 16 characters. Each line has 16 characters, and each line contains 20 characters.

5 CIRCUIT DIAGRAM

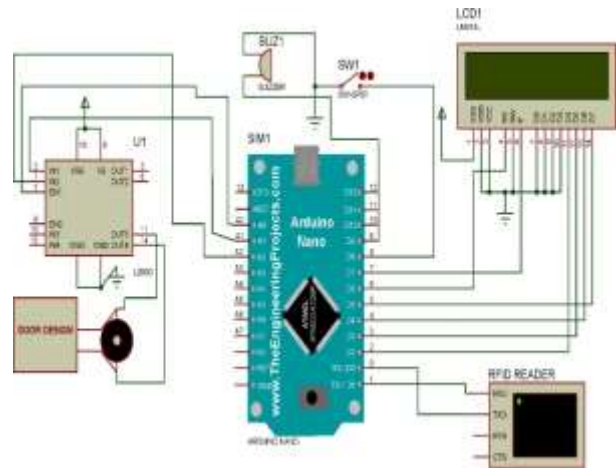

E. Buzzer

Autos, home appliances like microwaves, and game shows all use buzzers or beepers as electrical signaling devices. One or more switches and sensors are normally linked to a control unit, which identifies whether a button has been pressed and which one. The relevant light on the button or control panel is then illuminated, and an alarm is then sent in the form of a constant beeping sound. This is the most common configuration. Instead of using a metal gong, the original design relied on an electromechanical mechanism that was almost comparable to that found in an electric bell. These devices were often mounted on a wall or ceiling and acted as a kind of resonator. In certain AC-connected gadgets, a loudspeaker was linked to an inexpensive 8-ohm speaker through a circuit that made the AC sound loud enough to drive the speaker. Like a SON-ALERT, a high-pitched ceramic piezoelectric sounder is becoming more commonplace these days. Their pitch or pulse width might be manipulated or pulsed on and off using "driving" circuits. It's also known as a "lockout mechanism" in video games since once someone signals ("buzzes in"), no one else can signal. Plungers are huge buzzer buttons that appear on several game programs. The buzzing sound it made when driven by stepped-down AC line voltage at 50 or 60 Hz gave rise to the buzzer's moniker. It's also possible to use a bell or a buzzer to indicate that you've pressed a button.

F Arduino IDE

In addition to the text editor, the Arduino IDE includes a message box, a text terminal, a toolbar with basic function buttons, and menus. It can communicate with the Arduino and Genuino boards through the hardware connection and upload apps.

The figure depicts the based smart shopping trolley PROTOTYPE circuit, which consists of an Atmega328 microcontroller, 16x2 LCD, RFID Reader, and Tag as well as buttons to change the modes of the trolley circuit; in the first mode, it is used to calculate the products in a cart and the cost of the product; in the second mode, while pressing the button, the overall cost of the product and it to be uploaded to the user system, The smart trolley is embedded with the door mechanism where the product automatically falls on the trolley where the product is valid it falls on a trolley where again it closes, if the product is not valid or expired the door does not open, the user may view and access their grocery item selection, payment method, and the attendee's ID and trolley number. It may be used to gather several grocery lists, add them to the customer's existing shopping list, and assign each list to a certain attendee and trolley number.

6 CONCLUSION

The intended objectives were successfully achieved in the prototype model developed. The developed product is easy to use, economical, and does not require any special training. This project simplifies the billing process, makes it swift & increases security using the RFID technique. This will take the overall shopping experience to a different level.

7 FUTURE SCOPE

In the future, we can pay the bill amount online by using the smartphone by scanning the QR code of that particular supermarket. And get the soft copy of the bill receipt to check out from the supermarket.

8 REFERENCES

- [1] F. Xia, L. T. Yang, L. Wang, and A. Vinel, "Internet of things," *International Journal of Communication Systems*, vol. 25, no. 9, p. 1101, 2012.
- [2] P. Castillejo, J.-F. Martinez, J. Rodriguez-Molina, and A. Cuerva, "Integration of wearable devices in a wireless sensor network for an e-health application," *IEEE Wireless Communications*, vol. 20, no. 4, pp. 38–49, 2013.
- [3] N. Mitton, S. Papavassiliou, A. Puliafito, and K. S. Trivedi, "Combining cloud and sensors in a smart city environment," *EURASIP Journal on Wireless Communications and Networking*, vol. 2012, no. 1, p. 1, 2012.
- [4] T. Song, R. Li, X. Xing, J. Yu, and X. Cheng, "A privacy-preserving communication protocol for IoT applications in smart homes," in to appear in the *International Conference on Identification, Information and Knowledge in the Internet of Things (IIKI) 2016*, 2016.
- [5] S. Shepard, *RFID: radio frequency identification*. McGraw Hill Professional, 2005.
- [6] D. M. Dobkin, *The rf in RFID: UHF RFID in practice*. Newnes, 2012.
- [7] D. Klabjan and J. Pei, "In-store one-to-one marketing," *Journal of Retailing and Consumer Services*, vol. 18, no. 1, pp. 64–73, 2011.
- [8] T. Shanmugapriyan, "Smart cart to recognize objects based on user intention," *International Journal of Advanced Research in Computer and Communication Engineering*, vol. 2, no. 5, 2013.
- [9] R. Kumar, K. Gopalakrishna, and K. Ramesha, "Intelligent shopping cart," *International Journal of Engineering Science and Innovative Technology*, vol. 2, no. 4, pp. 499–507, 2013.
- [10] S. Gupta, A. Kaur, A. Garg, A. Verma, A. Bansal, and A. Singh, "Arduino based smart cart," *International Journal of Advanced Research in Computer Engineering & Technology*, vol. 2, no. 12, 2013.
- [11] Z. Ali and R. Sonkusare, "Rfid based smart shopping and billing," *International Journal of Advanced Research in Computer and Communication Engineering*, vol. 2, no. 12, pp. 4696–4699, 2013.
- [12] P. Chandrasekar and T. Sangeetha, "Smart shopping cart with automatic billing system through RFID and Zigbee," in *Information Communication and Embedded Systems (ICES), 2014 International Conference on*. IEEE, 2014, pp. 1–4.
- [13] M. R. Sawant, K. Krishnan, S. Bhokre, and P. Bhosale, "The RFID based smart shopping cart," *International Journal of Engineering Research and General Science*, vol. 3, no. 2, pp. 275–280, 2015.
- [14] A. Yewatkar, F. Inamdar, R. Singh, A. Bandal, et al., "Smart cart with automatic billing, product information, product recommendation using RFID & Zigbee with anti-theft," *Procedia Computer Science*, vol. 79, pp. 793–800, 2016.
- [15] Z. Cai, Z. He, X. Guan, and Y. Li, "Collective data-sanitization for preventing sensitive information inference attacks in social networks," *IEEE Transactions on Dependable and Secure Computing*, 2016.
- [16] Z. He, Z. Cai, Q. Han, W. Tong, L. Sun, and Y. Li, "An energy-efficient privacy-preserving content sharing scheme in mobile social networks," *Personal and Ubiquitous Computing*, vol. 20, no. 5, pp. 833–846, 2016.
- [17] L. Zhang, Z. Cai, and X. Wang, "Fakemask: A novel privacy-preserving approach for smartphones," *IEEE Transactions on Network and Service Management*, vol. 13, no. 2, pp. 335–348, 2016.